

# ELECRAFT® K3

## HIGH-PERFORMANCE 160 – 6 METER TRANSCEIVER

### KSYN3A SYNTHESIZER INSTALLATION INSTRUCTIONS

Rev A3, March 31, 2015

Copyright © 2015, Elecraft, Inc.

All Rights Reserved

# Contents

Introduction.....	3
Firmware Required.....	3
Checking Synthesizer Types .....	3
Synthesizer Calibration .....	4
Customer Service and Support .....	4
Technical Assistance .....	4
Repair / Alignment Service .....	4
Preventing Electrostatic Discharge Damage .....	6
Choosing an Anti-Static Mat.....	6
Preparing for Installation .....	7
Tools Required .....	7
Parts Included.....	7
Installation Procedure .....	8
Removing the Top Cover .....	8
K144XV Option .....	9
Replacing the Synthesizer(s).....	10
Reassembling the K3.....	16
Perform the <i>Initial Checks</i> on the next page to ensure your KSYN3A synthesizer(s) are operating properly.	18
Initial Checks .....	19
Transmit Gain Calibration.....	19

# Introduction

This manual will guide you through the replacement of the KSYN3 synthesizer(s) in your K3 transceiver with the new KSYN3A synthesizer(s). No test equipment is required. Only a few hand tools are needed to assemble your kit (see page *Tools Required* on page 7).

Basic K3s have one synthesizer. If you have the optional KRX3 Subreceiver installed in your K3 there will be two synthesizers and you must order a second KSYN3A Upgrade kit. If your K3 has both synthesizers, they both must be the same type. Following the instructions in this manual you can replace both synthesizers at the same time.

**⚠ You cannot have a new KSYN3A synthesizer and the original KSYN3 in the same K3! If you have the KRX3 sub receiver installed, you must install two KSYN3A synthesizers.**

Should you have difficulty, you'll have our full support via phone and e-mail. In addition, we hope you'll join our growing and enthusiastic community of owner/builders via the Elecraft reflector.

## Firmware Required

The new KSYN3A synthesizers require your K3 be equipped with firmware version 5.14 or later. If needed, see *Firmware Upgrades* in your K3 Owner's Manual for details about how to upgrade your firmware.

## Checking Synthesizer Types

If you are unsure which synthesizer is installed in your K3, open the K3 top cover (see *Removing Top Cover* on page 8). You don't need to remove the top cover completely. Only lift it far enough to see the synthesizers (see Figure 1). The old and new synthesizers are shown in Figure 2.

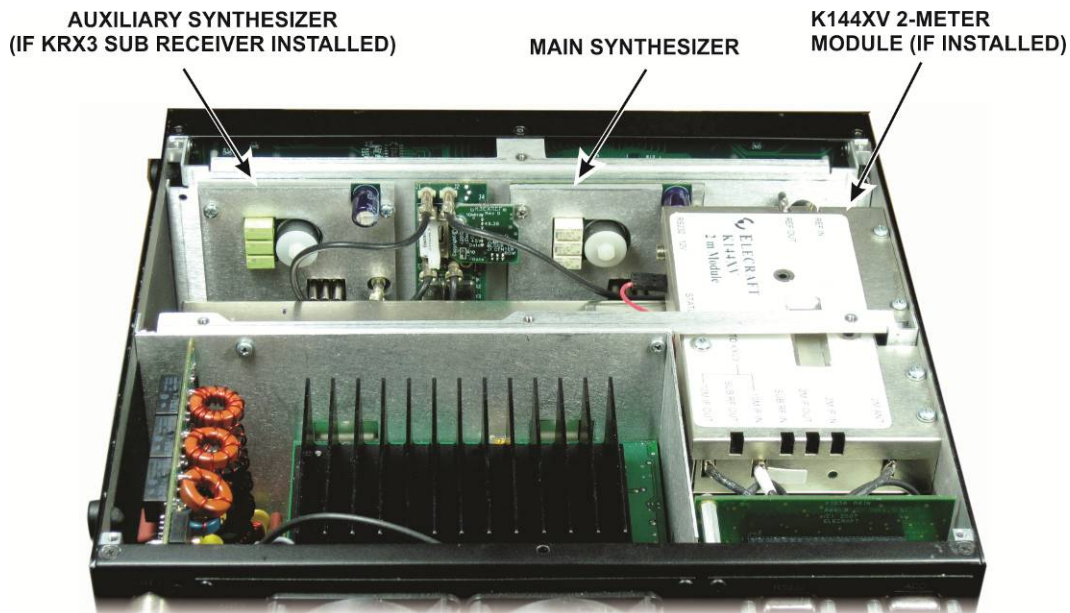

Figure 1. Synthesizer Locations in the K3.

**⚠** The new KSYN3A boards are shipped in ESD-safe envelopes. Do not handle them without first taking the ESD precautions listed on page 6. Keep the synthesizers you remove in those envelopes.

Like the original synthesizer, one pin of the multi-pin connector at the bottom has been cut and the corresponding opening in the socket on the K3 RF board has been plugged to assist in properly aligning the connectors when installing the board.

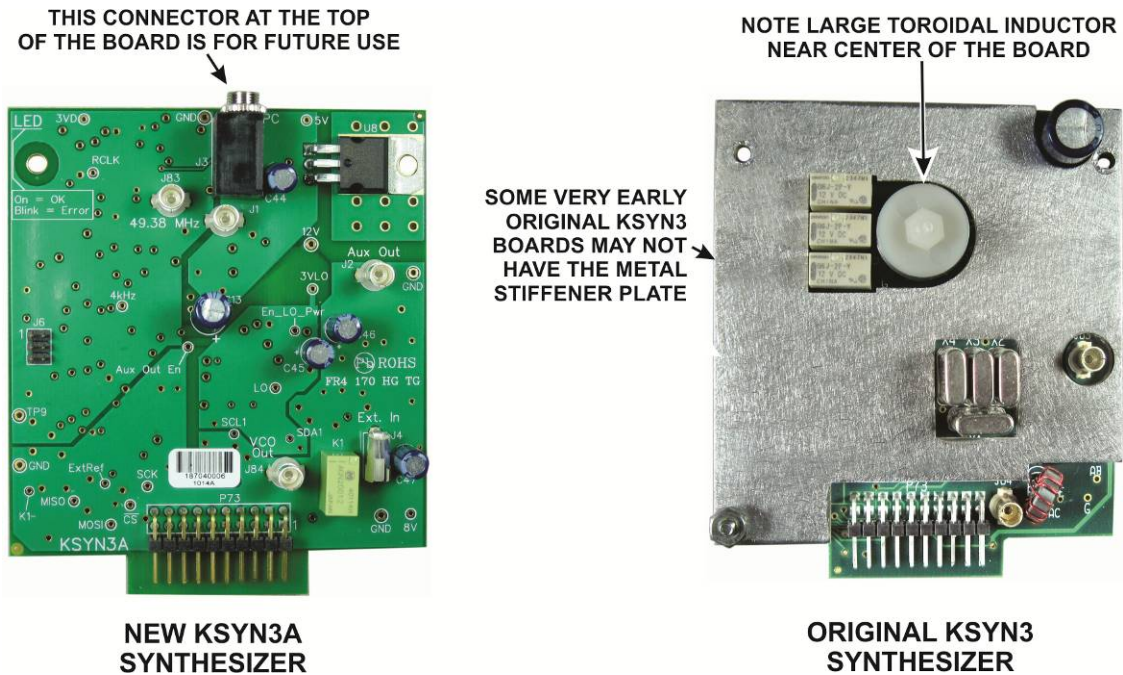

Figure 2. Original and New Synthesizer Boards.

## Synthesizer Calibration

The original KSYN3 synthesizers required calibration as described in your K3 Owner's Manual. **The new KSYN3A synthesizers do not require calibration.** The K3's *CONFIG:VCO MD* and *CONFIG:DDS FRQ* menu entries will each display two dashes - - instead of the values shown with the original synthesizers.

## Customer Service and Support

### Technical Assistance

You can send e-mail to [k3support@elecraft.com](mailto:k3support@elecraft.com) and we will respond quickly – typically the same day Monday through Friday. If you need replacement parts, send an e-mail to [parts@elecraft.com](mailto:parts@elecraft.com). Telephone assistance is available from 9 A.M. to 5 P.M. Pacific time (weekdays only) at 831-763-4211. Please use e-mail rather than calling when possible since this gives us a written record of the details of your problem and allows us to handle a larger number of requests each day.

### Repair / Alignment Service

If necessary, you may return your Elecraft product to us for repair or alignment. (Note: We offer unlimited email and phone support, so please try that route first as we can usually help you find the problem quickly.)

**IMPORTANT:** You must contact Elecraft before mailing your product to obtain authorization for the return, what address to ship it to and current information on repair fees and turnaround times. (Frequently we can determine the cause of your problem and save you the trouble of shipping it back to us.) Our repair location is different from our factory location in Aptos. We will give you the address to ship your kit to at the time of repair authorization. Packages shipped to Aptos without authorization will incur an additional shipping charge for reshipment from Aptos to our repair depot.

### **Elecraft 1-Year Limited Warranty**

This warranty is effective as of the date of first consumer purchase (or if shipped from the factory, the date the product is shipped to the customer). It covers both our kits and fully assembled products. For kits, before requesting warranty service, you should fully complete the assembly, carefully following all instructions in the manual.

**Who is covered:** This warranty covers the original owner of the Elecraft product as disclosed to Elecraft at the time of order. Elecraft products transferred by the purchaser to a third party, either by sale, gift, or other method, who is not disclosed to Elecraft at the time of original order, are not covered by this warranty. If the Elecraft product is being bought indirectly for a third party, the third party's name and address must be provided at time of order to ensure warranty coverage.

**What is covered:** During the first year after date of purchase, Elecraft will replace defective or missing parts free of charge (post-paid). We will also correct any malfunction to kits or assembled units caused by defective parts and materials. Purchaser pays inbound shipping to us for warranty repair; we pay shipping to return the repaired equipment to you by UPS ground service or equivalent to the continental USA and Canada. For Alaska, Hawaii, and other destinations outside the U.S. and Canada, actual return shipping cost is paid by the owner.

**What is not covered:** This warranty does not cover correction of kit assembly errors. It also does not cover misalignment; repair of damage caused by misuse, negligence, battery leakage or corrosion, or builder modifications; or any performance malfunctions involving non-Elecraft accessory equipment. The use of acid-core solder, water-soluble flux solder, or any corrosive or conductive flux or solvent will void this warranty in its entirety. Also not covered is reimbursement for loss of use, inconvenience, customer assembly or alignment time, or cost of unauthorized service.

**Limitation of incidental or consequential damages:** This warranty does not extend to non-Elecraft equipment or components used in conjunction with our products. Any such repair or replacement is the responsibility of the customer. Elecraft will not be liable for any special, indirect, incidental or consequential damages, including but not limited to any loss of business or profits.

# Preventing Electrostatic Discharge Damage

Sensitive components may be damaged by Electrostatic Discharge (ESD) simply by touching them or a circuit board containing them unless you take specific steps to prevent such damage. Damage may occur with static discharges far too little for you to notice.

A damaged component may not fail completely at first. Instead, the damage may result in below-normal performance for an extended period of time before you experience a total failure.

Parts which are especially ESD-sensitive are identified in the parts list and in the assembly procedures.

We strongly recommend you take the following anti-static precautions (listed in order of importance) to ensure there is no voltage difference between the components and any object that touches them:

- Leave ESD-sensitive parts in their anti-static packaging until you install them. The packaging may be a special plastic bag that allow static charges to flow harmlessly over their surface, or a component's leads may be inserted in conductive foam that keep them at the same potential.
- Wear a conductive wrist strap with a series 1-megohm resistor that will constantly drain off any static charge that accumulates on your body. If you do not have a wrist strap, touch a ground briefly before touching any sensitive parts to discharge your body. Do this frequently while you are working. You can collect a destructive static charge on your body just sitting at the work bench.

## **WARNING**

**DO NOT attach a ground directly to yourself without a current-limiting resistor as this poses a serious shock hazard. A wrist strap must include a 1-megohm resistor to limit the current flow. If you choose to touch an unpainted, metal ground to discharge yourself, do it only when you are not touching live circuits with any part of your body.**

- Use a grounded anti-static mat on your work bench (see below).
- If you pick up a pc (printed circuit) board that was not placed on an anti-static mat or in an anti-static package, first touch a ground plane connection on the board such as a connector shell or mounting point.
- If you use a soldering iron to work on a circuit board, be sure your iron has an ESD-safe grounded tip tied to the same common ground used by your mat and wrist strap.

## Choosing an Anti-Static Mat

An anti-static mat must bleed off any charge that comes in contact with it at a rate slow enough to avoid a shock or short circuit hazard but fast enough to ensure dangerous charges cannot accumulate. Typically, a mat will have a resistance of up to 1 Gigaohm ( $10^9$  ohms). Testing a mat requires specialized equipment, so we recommend that you choose an anti-static mat that comes with published resistance specifications and clean it as recommended by the manufacturer. Testing has shown that many inexpensive mats that do not specify their resistance have resistance values much too high to provide adequate protection, even after they were cleaned and treated with special anti-static mat solutions.

Suitable anti-static table mats are available from many sources including:

- U-line (Model 12743 specified at  $10^7$  ohms)
- Desco (Model 66164, specified at  $10^6$  to  $10^8$  ohms)
- 3M™ Portable Service Kit (Model 8505 or 8507, specified at  $10^6$  to  $10^9$  ohms)





# Preparing for Installation

## Tools Required

1. ESD Protection (see Preventing Electrostatic Discharge Damage, pg 6)
2. #1 size Phillips screwdriver. Some makes of size #0 screwdriver may fit better. Always use the screwdriver that best fits the screw in each step. To avoid damaging screws and nuts, a power screwdriver is not recommended.
3. Side (diagonal) cutters, flush-cut type preferred.
4. Small needle nose pliers or tweezers for holding small parts in tight spaces (see Figure 7 on page 10).
5. A magnet on a rod (or magnetized screwdriver) is handy to retrieve a dropped part if needed.

## Parts Included

The following parts should be included in your kit. Check to ensure you have them all. If any parts are damaged or missing, contact Elecraft for replacements (see *Customer Service and Support* on page 4).

ILLUSTRATION	DESCRIPTION	QTY.	ELECRAFT PART NO.
	KSYN3A Printed Circuit Board <b>⚠ ESD Sensitive. Follow ESD safe handling procedures. Keep in ESD-safe bag until installed.</b> One pin on the multi-pin connector has been removed intentionally.	1	E850638
	TMP Cable 10" (25 cm)	1	E850338
	Screw, 4-40, 1/4" (6.4 mm) Zinc, Pan Head.	2	E700005
	Lock Washer, #4, Interior Tooth	2	E700010

# Installation Procedure

## Removing the Top Cover

Disconnect power and all cables from your K3.

Remove the nine screws to free the top cover as shown in Figure 3. After the cover is open, lift it gently to reach the speaker wire connector. Unplug the speaker then set the top cover aside in a safe place.

**⚠ Whenever you remove screws from a panel, if one screw seems too tight to loosen without damaging it, first loosen the other screws then try again. Sometimes one screw binds in its hole when the other screws are tightened.**

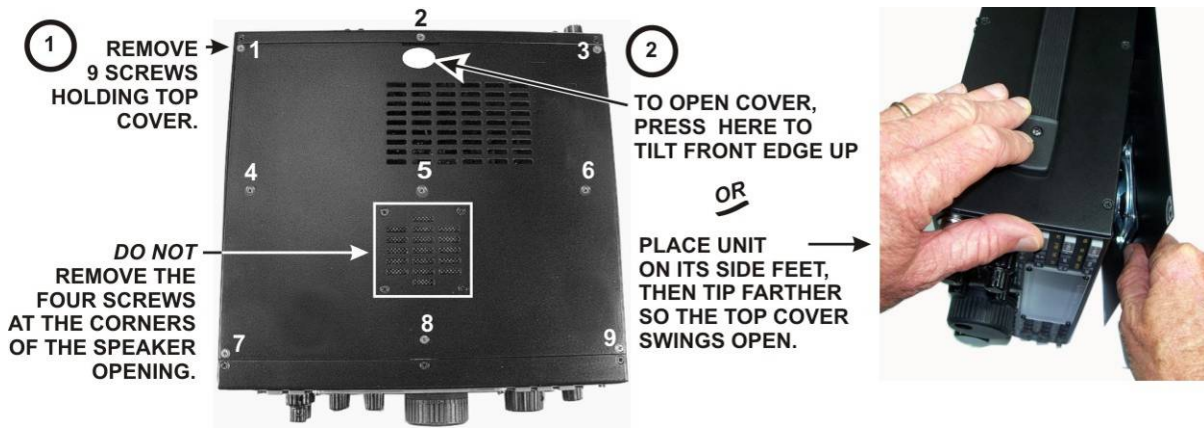

Figure 3. Removing K3 Top Cover.

## **⚠ CAUTION**

**Touch an unpainted metal ground or wear a grounded wrist strap before touching components or circuit boards inside the K3. See Preventing Electrostatic Discharge on page 6 for more information.**



## K144XV Option

If your K3 does not have the K144XV 2-meter module option installed go to *Replacing the Synthesizer(s)* on page 10. Otherwise, move the 2-meter module out of the way as follows:

- Remove the stiffener as shown in Figure 4. It will be held in place by a flat head screw through each side panel. If the KPA3 100 watt amplifier option is installed, two screws securing it to the KPA3 shield. Some older K3s may use nuts and lock washers on the screws securing the stiffener to the KPA3 shield instead of PEM nuts.

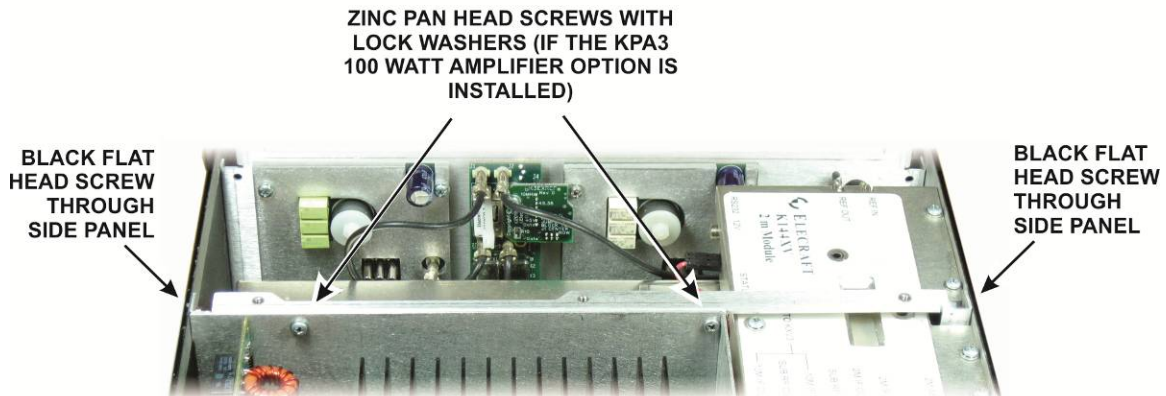

Figure 4. Removing the Chassis Stiffener.

- Remove the three screws that hold the K144XV module to the side panel (see Figure 5). You do not need to remove the module but only free it so it can be moved back away from the main synthesizer board far enough to gain access to it.

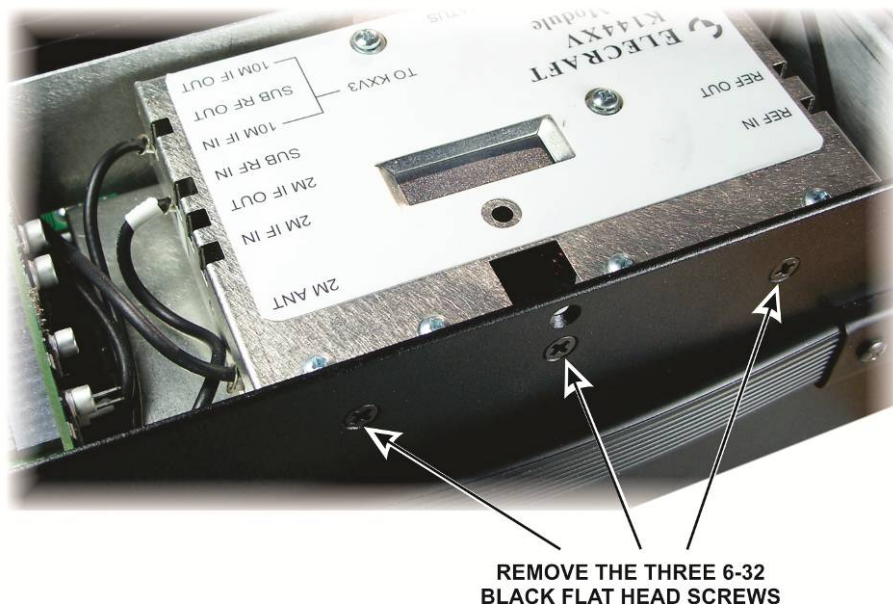

Figure 5. Removing the K144XV Module Mounting Screws.

- You can either unplug the coaxial cables or push the module aside to reach the mounting screw for the main synthesizer board. To remove the cables, first remove the five screws securing the top cover and lift it off so you can pull on the metal grip of each connector (see Figure 6). Do not pull on the coaxial cable; you might pull it out of the TMP connector. If you remove it completely, a diagram is provided on page 14 showing all of the required cable connections to reinstall it.

## Replacing the Synthesizer(s)

**⚠ CAUTION:** The synthesizer mounting screws use two lock washers, one between the pc board and the front panel shield and one under the screw head. Do not lose the lock washers inside the K3. Some builders find it easier to stand the K3 on one side so a dropped lock washer does not fall down onto the main RF board covering the bottom.

Unplug the coaxial cables from the synthesizer. The connectors are a friction fit and pull apart. Pull on the metal “ears” of the TMP connectors, not on the coaxial cable (see Figure 6).

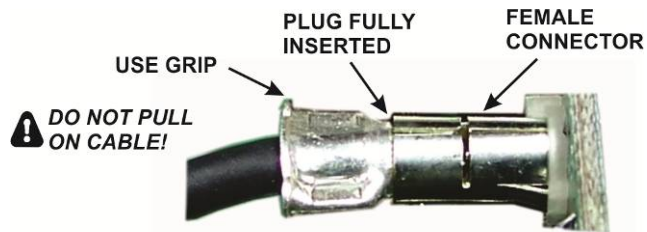

Figure 6. TMP Cable Connectors.

Loosen the two mounting screws at the top of the synthesizer board. Do not remove the screws completely until you have loosened both of them and located the lock washer between the pc board and the front panel shield. Slide the split-ring lock washer on each screw toward the pc board and then carefully finish unscrewing each screw (see Figure 7) Once the screw is clear of the threaded PEM nut on the front panel shield you can carefully grab the split ring lock washer with your needle nose pliers and remove it, then remove the screw and remaining lock washer. It helps to remove both screws a few turns at a time so you have the greatest amount of room to reach in and grab the lock washer while the other screw is still partially threaded into the PEM nut. If your K3 is equipped with the K3EXREF option, the distance you can pull the synthesizer away from the front panel shield is limited but there is still adequate clearance (see Figure 8).

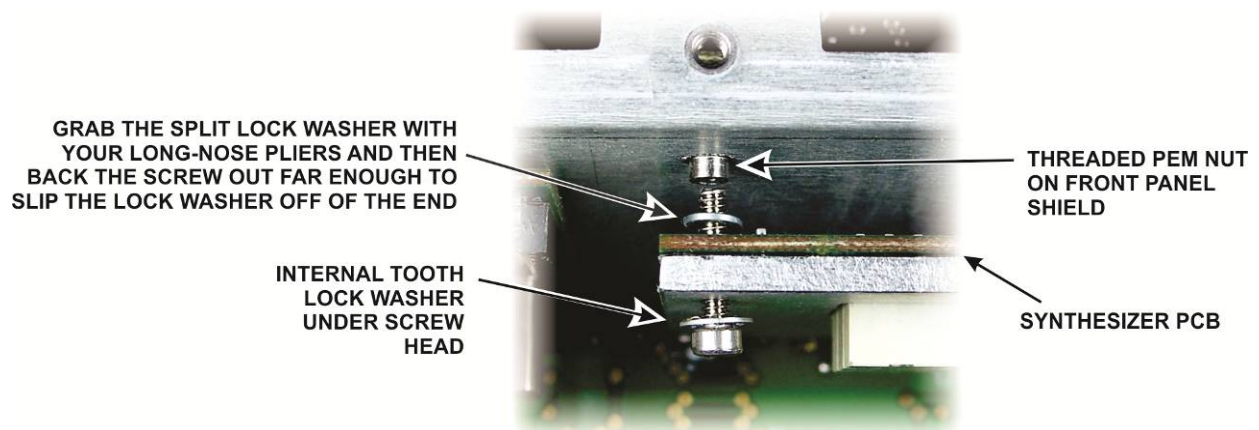

Figure 7. Removing Synthesizer Mounting Screws.

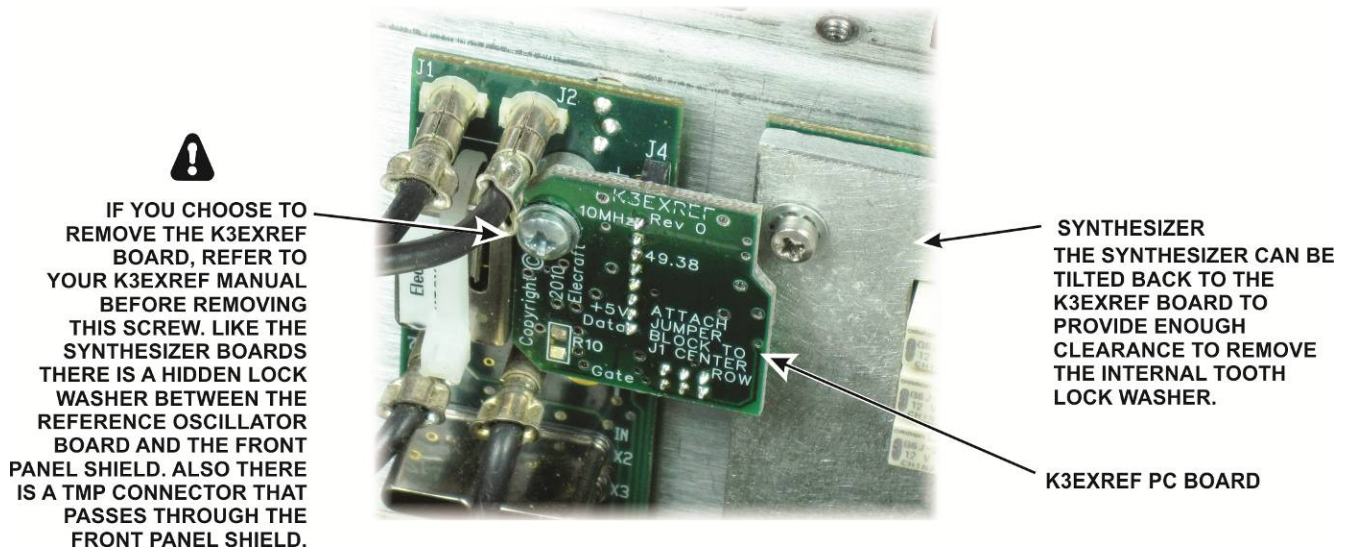

Figure 8. K3EXREF Board Option.

Remove the replacement KSYN3A synthesizers from their envelopes. You will have two synthesizers only if your K3 is equipped with the KRX3 Subreceiver option. Inspect the back of each board for long leads, especially those associated with the mini-connector and U8 near the top of the board. Carefully trim these leads flush with the board as shown in Figure 9.

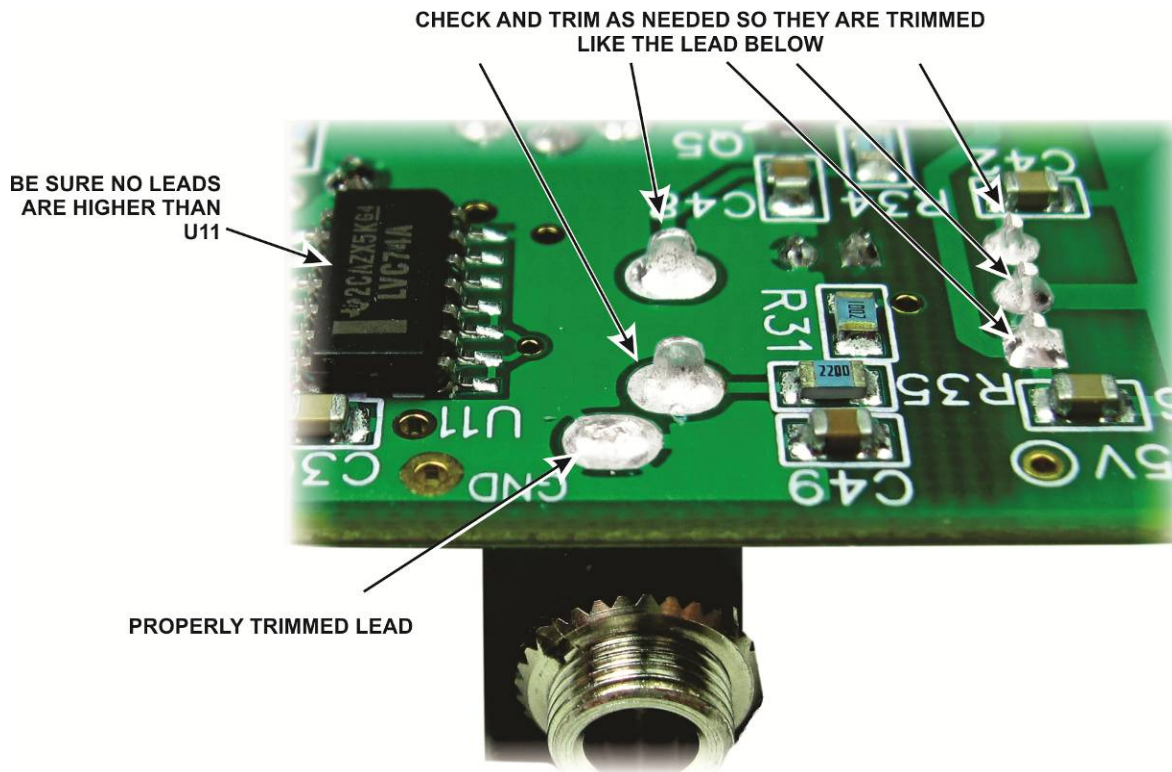

Figure 9. Trimming Synthesizer Leads.



□ If your K3 has the KRX3 sub receiver, install the auxiliary synthesizer as follows:

1. First attach two coaxial cables to the pc board before installing it as shown in Figure 11. Connecting these now will simplify connecting them later in the tight space between the sub receiver enclosure and the synthesizer.
2. With the two coaxial cables connected, install the synthesizer just as you did the main synthesizer, using the screws supplied with the KSYN3A board and the interior tooth lock washers you removed earlier (see Figure 10).

**⚠ Do not replace the lock washers behind the KSYN3A board. Like the main synthesizer, the board rests directly against the PEM nuts on the front panel shield.**

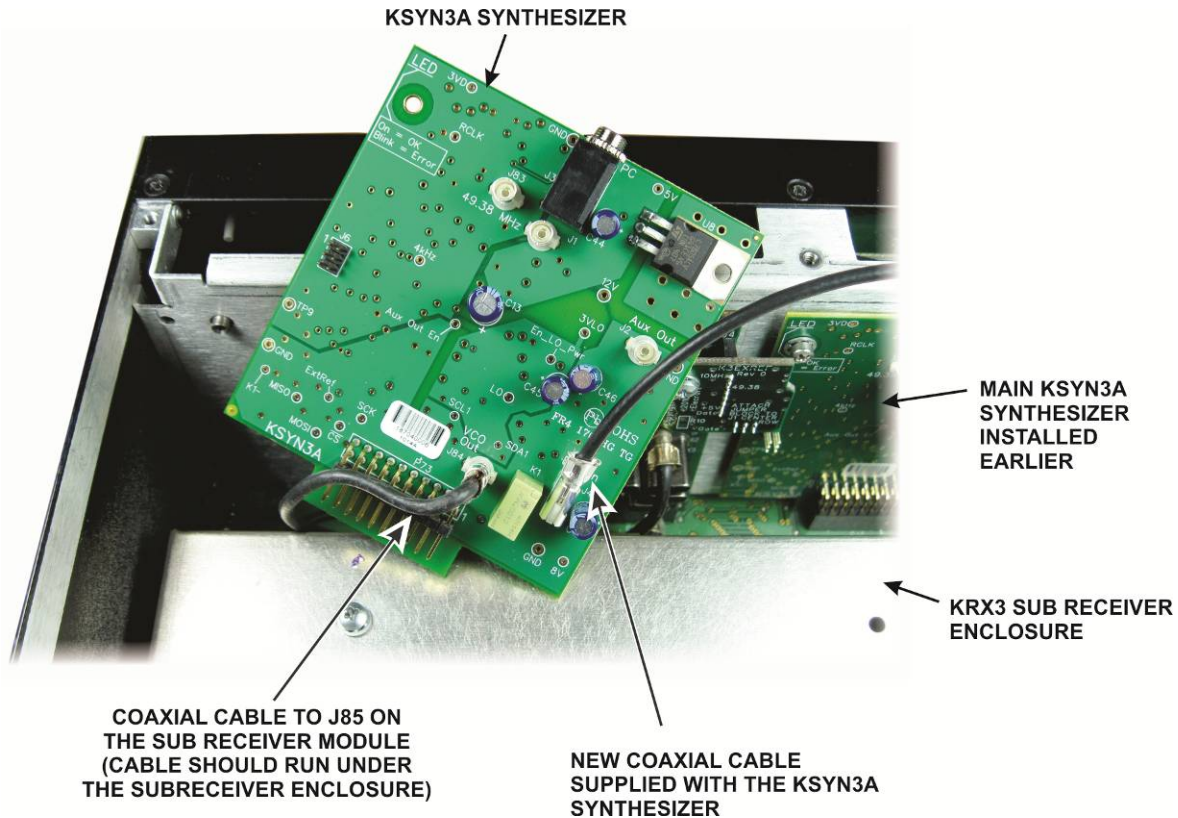

Figure 11. Preparing to Install the Auxiliary Synthesizer.

☐ Complete installing the coaxial cables connected as shown in Figure 12 if your K3 does not include the KRX3 sub receiver or Figure 13 if your K3 has the KRX3 sub receiver.

Note that:

1. The cables shown in gray do not change. They are shown in case one becomes disconnected from the KREF3 board while you are working.
2. If you do not have the KRX3 sub receiver, you will not use the 10" cable supplied with your new KSYN3A synthesizer.
3. If you have the K144XV 2-meter option with the reference oscillator phase lock option installed, you now have only one coaxial cable instead of two cables as before. If you removed the K144XV top cover to disconnect the other coaxial cables from the K144XV module, do not plug the cable into REF IN until you are instructed to replace the module in the following steps. That cable must pass through a hole in the K144XV top cover.
4. No connection is made to the large connector at the top of the new KSYN3A board(s). This connector is for future use.

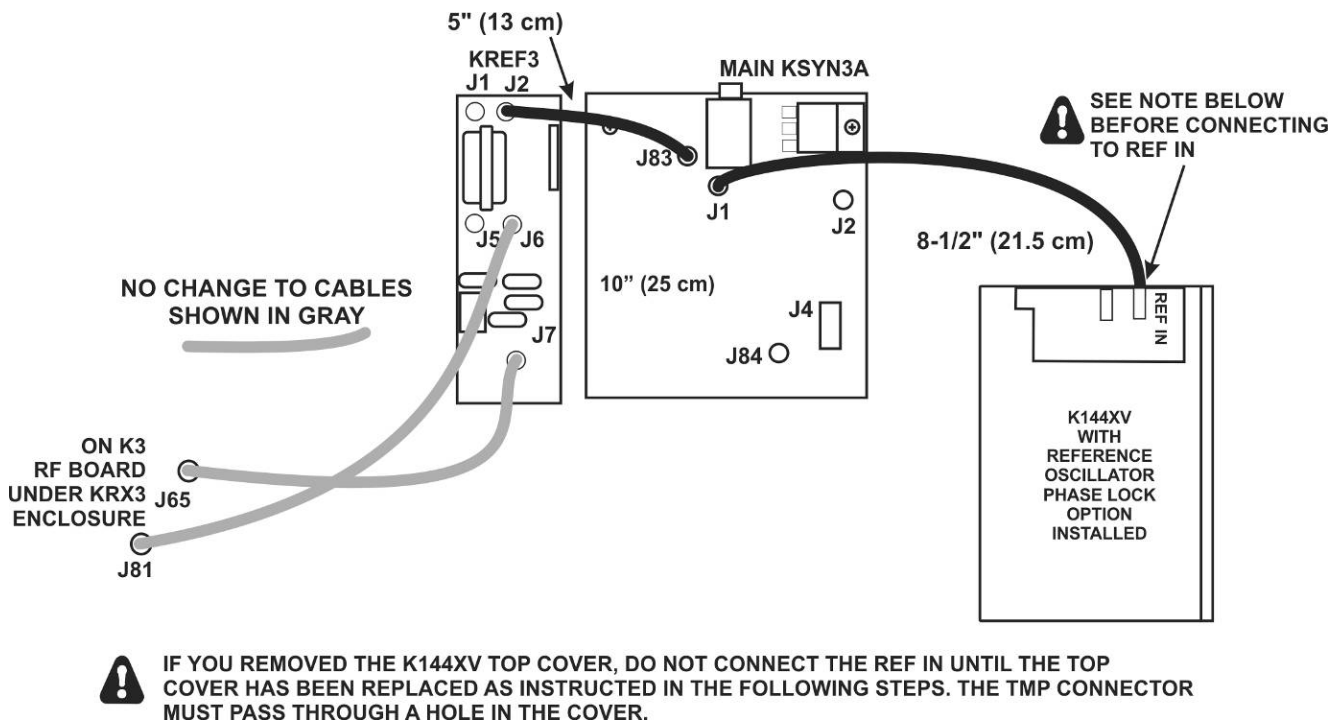
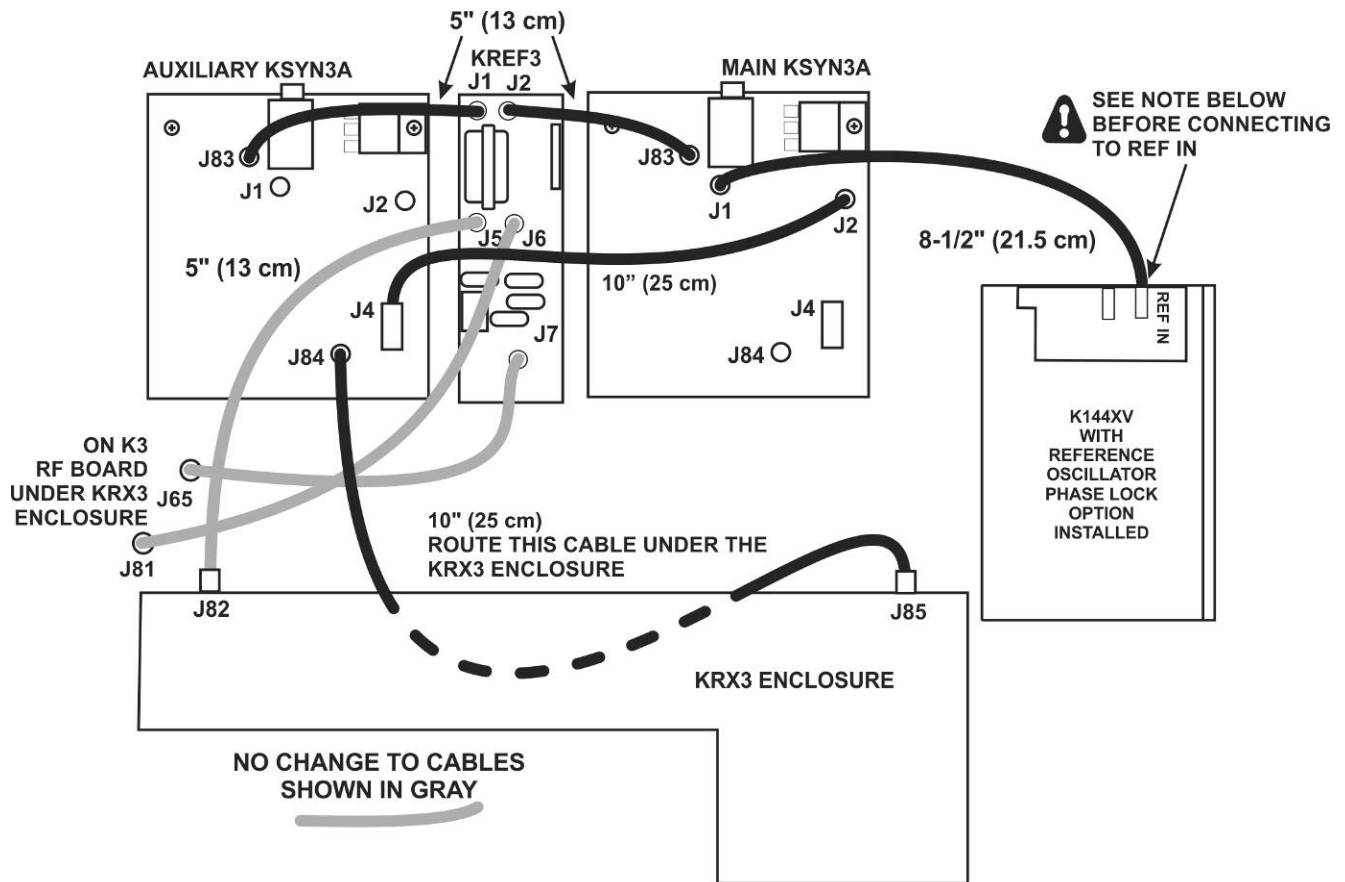

Figure 12. Coaxial Cable Connections for K3 with no KRX3 Sub Receiver.



**!** IF YOU REMOVED THE K144XV TOP COVER, DO NOT CONNECT THE REF IN UNTIL THE TOP COVER HAS BEEN REPLACED AS INSTRUCTED IN THE FOLLOWING STEPS. THE TMP CONNECTOR MUST PASS THROUGH A HOLE IN THE COVER.

Figure 13. Coaxial Cable Connections for K3 with KRX3 Sub Receiver.

## Reassembling the K3

If you have the K144XV 2-meter option installed:

1. Reconnect any coaxial cables you removed (see Figure 14), but do not connect the REF IN cable from the main KSYN3A.
2. Replace the cover and attach with the five 4-40 1/4" (6.4 mm) zinc pan head screws and internal tooth lock washers you removed earlier.
3. If you removed the K144XV from the side panel, remount it with the three 6-32 black flat head screws you removed earlier.

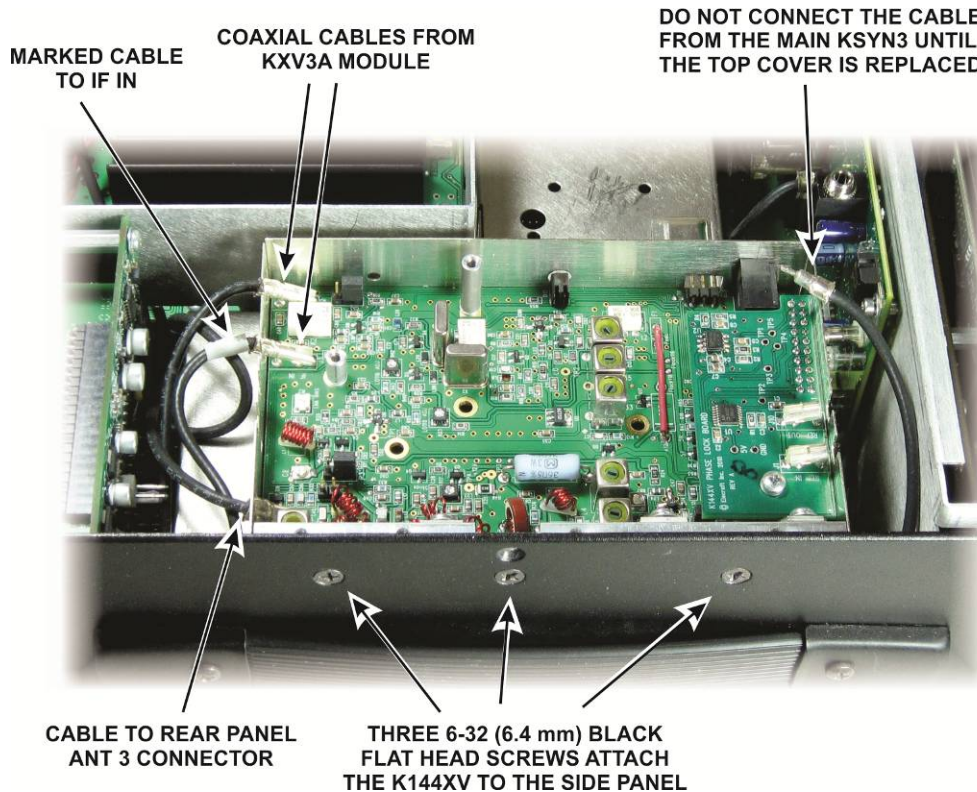

Figure 14. Replacing the K144XV Module.



If you have the K144XV 2-meter module installed, connect the coaxial cable from the main KSYN3A synthesizer board to REF IN as shown in Figure 15. Also reconnect the power cable as shown.

If you have the KRX3 subreceiver installed, dress the coaxial and power cables as shown in Figure 15. The area on top of the KRX3 enclosure must be clear of all wires and cables as shown for the K3 top to fit properly.

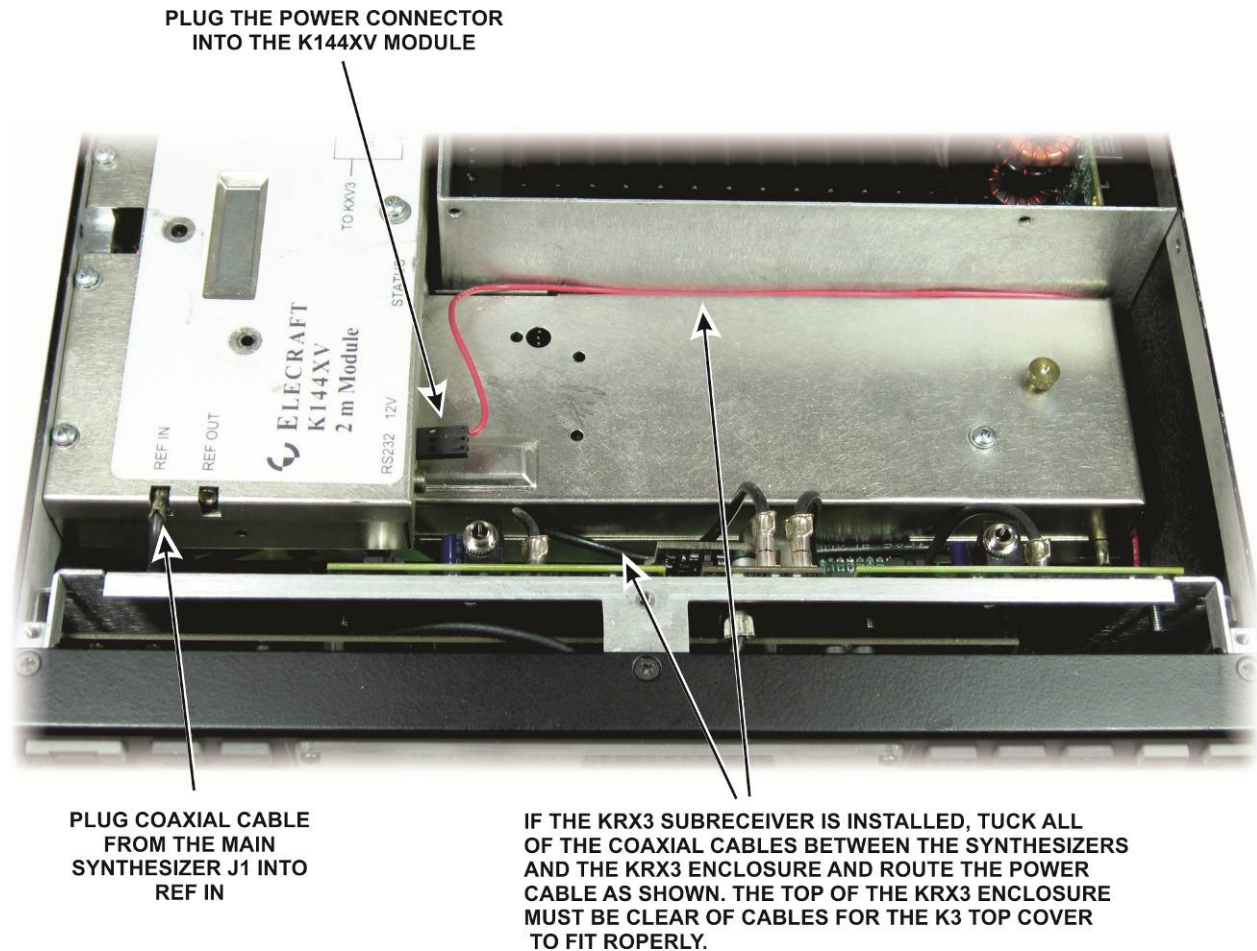

Figure 15. Connecting and Dressing the Cables.

If you removed the chassis stiffener (see Figure 4 on page 9) replace it now. If you have the KPA3 100-watt option installed, be sure to replace the two screws that attach the stiffener to the KPA3 shield.

**⚠** If you have the KRX3 sub receiver installed, be sure you installed the new coaxial cable between J4 on the Auxiliary KSYN3A synthesizer and J2 on the Main KSYN3A synthesizer (See Figure 11 and Figure 14) before continuing. The sub receiver will not work if you leave that cable out.

- If you have the K144XV option installed, hold the top cover above the K3, route the speaker wire under the stiffener bar at the depression in the top of the K144XV module as shown in Figure 16.

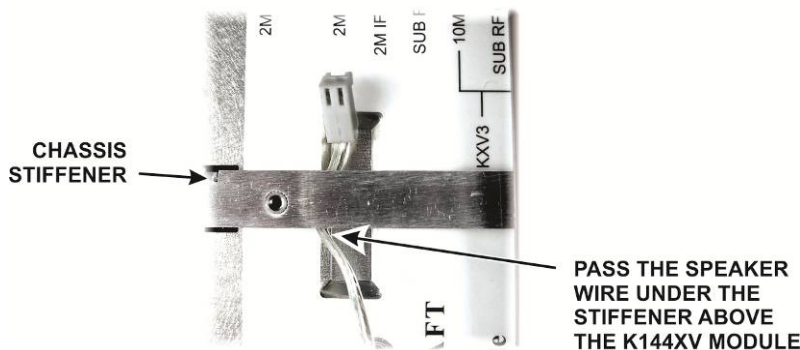

Figure 16. Routing the Speaker Wire Under the Chassis Stiffener.

- Plug the speaker wire into P25 on the KIO3 board at the left rear of the K3 as shown in Figure 17.

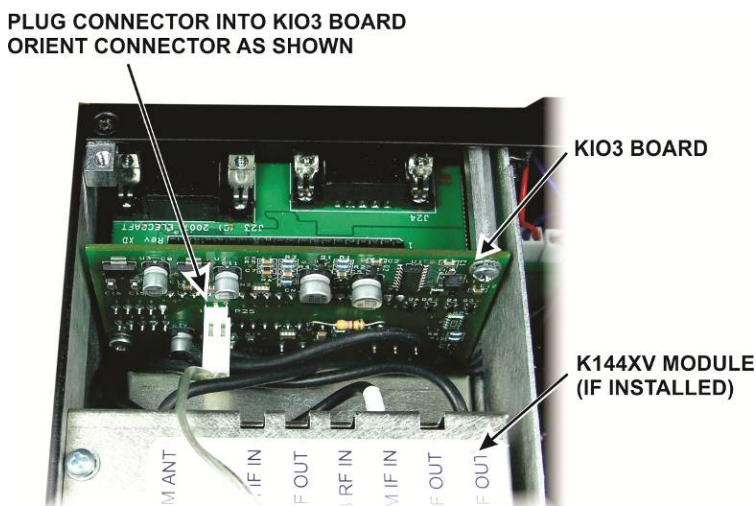

Figure 17. Plugging the Speaker Wire into the KIO3 Board.

- Position the top cover on the K3. Note that the tab on the back center goes under the rear lip of the K3 rear panel. Secure the top cover with the nine 4-40 3/16" (4.8 mm) black flat head screws you removed earlier (see Figure 3 on page 8 for the screw locations).

### **⚠ REPLACE ALL THE SCREWS!**

**The K3's chassis has excellent rigidity despite its light weight. The screws that hold the top cover in place are an important part of the structural design. Please be sure to replace all the screws and verify they are tight whenever you replace the cover or other panels**

- Perform the Initial Checks on the next page to ensure your KSYN3A synthesizer(s) are operating properly.

## Initial Checks

- Apply power to the K3.
- Confirm that you have rev 5.14 or later firmware installed: On the K3 front panel, hold **CONFIG** and verify that *uC 05.14* or later (a higher number) appears in the VFO A area on the LCD. If not, refer to *Firmware Upgrades* in your K3 Owner's manual to download and install the latest firmware and then repeat these checks.
- While still in the **CONFIG** menu, turn tech mode on (*CONFIG: TECH MD ON*).
- Tap **MENU** to exit the menu and then tap **DISP** on the K3 front panel.
- Rotate the VFO B knob to display *SYN1* in the VFO B area of the display. You should see the status *OK*.
- If you have the Auxiliary KSYN3A installed for the KRX3 sub receiver, turn the VFO B knob further to display *SYN2 OK*. (If you do not have the auxiliary KSYN3A installed, you will see *SYN2\*FF* on the display.)

**⚠** If you see any characters other than *OK* for the status of an installed KSYN3A, the synthesizer is not working properly. Note the exact display and contact Customer Service and Support (see page 4) If you do not have the auxiliary KSYN3A installed, you will see *SYN3\*FF* when turning the VFO B knob to *SYN2*.

## Transmit Gain Calibration

If you have a K3 equipped with the 100 watt KPA3 internal amplifier, we strongly recommend that you re-run the 50 watt transmit gain calibration after you install your KSYN3A synthesizer(s). Failure to do so may result in low transmitter output on some bands. You can do the procedure manually as described under *High Power (50 W) TX Gain Calibration* in your K3 Owner's Manual or you can have the K3 Utility program do the calibration automatically as described in the K3 Utility Program Help.

That completes the installation of your new KSYN3A synthesizer(s).